

BUCHER
municipal

Bucher CityCat V20 Bucher CityCat V20e

The agile compact sweepers



Bucher CityCat V20

Bucher Municipal's flagship sweeper in the 2 m³ class.

The Bucher CityCat V20 offers an unmatched combination of articulated steering and a state-of-the-art Euro 6 diesel engine, three brushes, maximum suction power and an energy-saving fan for outstanding efficiency. With its low fuel consumption, reduced exhaust emissions and low noise levels, it's obvious why this sweeper should be part of any fleet for inner-city cleaning purposes.



Bucher CityCat V20e

Bucher Municipal's new all-electric sweeper.

The Bucher CityCat V20e is the second generation of electrically powered sweeping vehicles with a big plus. Here we utilize a custom-designed battery pack with the capacity to last a full 10-hour shift. Powerful but respectful to its surroundings, the Bucher CityCat V20e can also be used round the clock – such are its impressive low noise emissions. This is proven technology with minimal environmental impact, ready to use in small and confined spaces.



High performance **and productivity**

The new CityCat series is designed around our customers. With the selection of an Euro 6 engine or the specially designed Bucher Battery Pack, the sweeper and its all new Smart-Con operating concept in the spacious cabin are revolutionizing street cleaning.

For the Bucher CityCat V20e, the 22 kW on-board charger means that batteries can be recharged in just two to three hours at any public car-charging station. With a recuperation function, the high-voltage battery can be charged during deceleration, further extending the range. Thus, the range will be further extended.

The floating suction intake with patented mounting mechanism ensures maximum air velocity for

perfect sweeping results, no matter how uneven the surface. A more efficient, energy-optimized fan is equally no longer troubled by debris because of its placement.

The wide in diameter, straight suction pipe also belongs to the Bucher "DNA" and resulting in minimum risk of blockage and optimum air flow for trouble-free operation.

Tried and tested, the articulated steering provides exceptional agility, manoeuvrability and maximum directional stability, allowing the driver to concentrate fully on sweeping without worrying about manoeuvring. Therefore, these sweepers can efficiently and cost-effectively clean everything from the narrowest of passages to the largest of spaces.

High payload

Up to 2100 kg at 4800 kg GVW

HMI

Intuitive Smart-Con operation concept combined with CSense touch display

BBP

Specially designed Bucher Battery Pack tailored to the Bucher CityCat V20e

EU6 engine

Bucher CityCat V20, the only articulated sweeper with a Euro 6 engine

The Bucher CityCat V20 & V20e deliver



Smart-Con

Multi-functional armrest with smart start function combined with 4.3 inch driver display



Single wheel suspension

Ensures a unique and comfortable driving experience

CSense display

10.1 inch touch display with intuitive design for extended functions and information



Water volume 425 l

275 l fresh water volume with an additional 150 l service water tank

Floating suction intake

Patented mounting system combined with straight suction hose

2 m³

Hopper volume of 2 m³ with a discharge height of 1555 mm

Bucher gearbox

With torsen differential for the Bucher CityCat V20e



Hill Holder

For safe start-up on an incline with the Bucher CityCat V20e

Articulated steering

Great manoeuvrability with suction mouth always positioned in the direction of travel

Hydrostatic drive

The Bucher CityCat V20 can switch seamlessly from work mode to transit mode and make a safe start-up on an incline



Side brush arms

Maintenance-free brush arms with tilt compensation

Disc brakes

On front and rear axles

1999 mm

Under 2 m with retractable and knock-down beacons, allowing access to car parks and other confined spaces



Standard Euro 6 diesel engine

High capacity Bucher Battery Pack

22 kW on-board charger

Articulated steering

Pulled brush system with 3rd brush

2 m³, easy to clean hopper

Low environmental **impact**

Low noise

Bucher CityCat V20e 92 dB(A) / CityCat V20 97 dB(A)
Innovative hydraulic unit with silent pumps significantly reduces noise emissions.

Low water usage

A water recirculation system reuses service water which is fed to the suction intake via the service water tank. This reduces refilling costs and extends on-station time.

Dust emissions

EUnited 4 star certified for PM10 and PM2.5

Latest regulation engine

For the Bucher CityCat V20:
Standard Euro 6 engine - with diesel particulate filter, SCR and water heated AdBlue system

Dust suppression

Water jets, adjustable from the cabin, on each brush provide a fine clean water spray to trap dust particles lifted by the two (optional three) brushes. In addition, service water is fed into the suction intake.

Electric drive

With our all-electric Bucher CityCat V20e sweeper, sustainability remains a key focus. Bucher Municipal has specially created a custom-designed Bucher Battery Pack that's tailored to the sweeper. This proven technology subjects minimal footprint to the environment and provides very low noise emissions.

Bucher Connect

Enables a reduction of fuel or energy cost while increasing productivity.

Euro 6

Bucher CityCat V20 with the latest emission standard diesel engine

PM10 and PM2.5

EUnited 4 star certified

Bucher Battery Pack

Zero emission



Safety and comfort

We believe all drivers should enjoy working with our sweepers, so we've introduced better suspension, soft-touch steering and Smart-Con with ergonomically perfected controls. Of course, safety is crucial. From the 3-point safety belts to the enhanced illumination of the sweeping area - ensuring a safe over-view for the driver and high visibility for third parties - it's our duty to take care.



- | | | |
|---|--|--|
| <p>1 Two full value seats with head-rest and 3-point safety belts on both driver and passenger seats, offering a comfortable and safe experience</p> | <p>4 4.3 inch display for overview of all automotive information, as well as setting feedback which pops up</p> | <p>7 Ergonomically designed workstation for enhanced operating experience in ROPS tested aluminium cabin</p> |
| <p>2 Excellent all-round view due to the continuous windscreen, all-glass doors and the two rear windows</p> | <p>5 Throttle and brake pedal positioned in-line for more foot room and increased movability</p> | <p>8 Low-energy LED lights to illuminate the sweeping area, ensuring a safe view and visibility for third parties</p> |
| <p>3 Intuitive, one-handed operation of the sweeper via an adjustable multi-function armrest allowing sweeping to start with the push of button</p> | <p>6 Gas spring-loaded steering column, adjustable in rake and reach for a tailored set-up</p> | <p>9 The 10.1 inch touch display for operating settings and functions enables extended setting possibilities and diagnostics of the vehicle</p> |



Smart-Con armrest
Multi-functional armrest with smart start function makes it possible to operate all working functions with one hand.



Smart-Con driver display
All relevant information and pop-up feedback at a glance at any time thanks to the digital 4.3 inch display.



CSense display
10.1 inch touch display with intuitive design for extended functions, central overview of all settings and visual diagnostic system. The displayed vehicle set-up can be individually chosen by the driver.



Seats
The cabin can be equipped with two fully fledged driver seats with headrests and 3-point safety belts to offer not just a comfortable driving experience, but also an ergonomic workstation.



Cab
Comfortably suspended, sound-insulated and ROPS tested aluminium cab. Windscreen made of heat-reflecting, curved, low-reflection safety glass.



Instrumentation
All switches are also within easy reach on the overhead console with the air-con controls.

Low cost of ownership

- Water recirculation system reuses the service water from the hopper and feeds this to the suction intake to minimize fill-ups and maximize on station time.
- Disc brakes on both axles are self-adjusting and reduce service time.
- Maintenance-free brush arms and low to no maintenance articulated steering.
- Maintenance free single wheel suspension on front axle and low maintenance heavy duty leaf springs on rear axle.
- Energy-saving LED Lights offer more powerful lighting while significantly reducing the number of times bulbs require replacement.
- Reduced number of greasing points with autolube option to save on servicing costs.
- Vulnerable nodes and electronic components protected up to IP69 standard and additional covers reduce risk of water ingress further.
- CSense display with full on-board diagnostics for easy fault finding and reduced downtime.
- Steel hydraulic pipes replace flexible hoses to reduce chaffing and premature hose wear.
- Hopper manufactured out of stainless steel for protection against corrosion and wear.



Specially designed Bucher Battery Pack with superior lifetime and no memory effect. Made with high quality automotive prismatic Li-ion NMC cells, managed through an automotive battery management system, the battery is placed in a shock, water and dust-proof case. The Bucher Battery Pack is maintenance-free and has a sophisticated repair concept for maximum safety. Due to the electric drive concept of the sweeper, maintenance and service costs in general are kept very low.

Bucher Connect

GO / GO+ /
BASE / PLUS / MAX

Hydraulic

Optimized design for
less maintenance

Service interval

Bucher CityCat V20
every 500 h
Bucher CityCat V20e
every 1000 h

LED lights

Energy-saving yet
powerful



Sweep and suction system

The Bucher CityCat V20 series models are designed so that the high-suction power hose is free to work harder. Optimized suction intake, fan placement and air flow direction in combination with the Bucher "DNA" pulled sweep gear and straight suction hose result in unmatched sweeper performance.

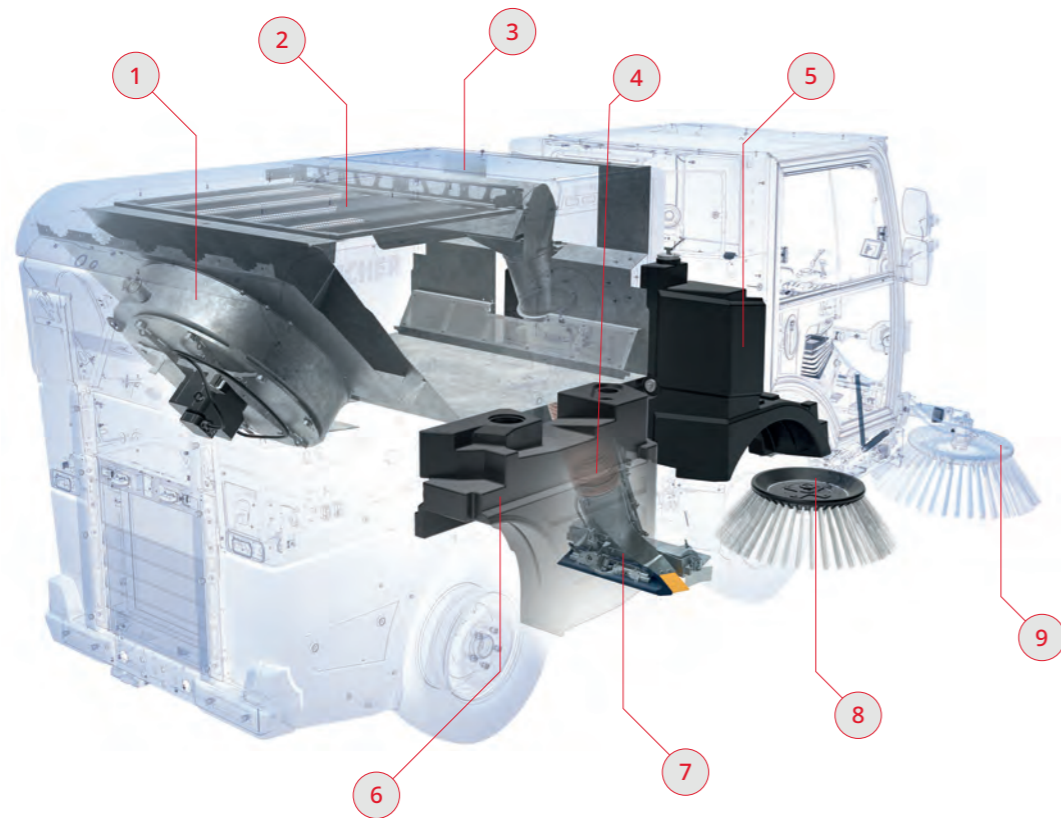

1 Optimised fan arrangement, with bigger, optimised blade wheels for greater efficiency

2 Easy to clean mesh in hopper to prevent clogging by leaves and debris

3 Large 2 m³ hopper with „EasyClean“ option available

4 Straight suction hose providing optimum air flow with minimum risk of blockage

5 Large 275 l fresh water volume for maximum operating times

6 150 l tank for used water (and optional fresh water extension) separated from hopper for easier cleaning and low point of gravity

7 Flow-optimised, floating suction mouth with patented mounting mechanism for uneven surfaces - ensures maximum air velocity for perfect sweeping results

8 Maintenance free sweep gear. 0-120 rpm, infinitely adjustable. Overlapping of suction mouth and brush due to unique brush arm design

9 Water nozzle for maximum dust suppression

Significant options



Seats

AGR certified driver seat with air suspension and passenger seat with mechanical or air suspension and headrest. Additional 3-point safety belt available for both seats.



3rd brush

This option significantly increases the sweeping width and flexibility. Telescopic or heavy duty universal 3rd brush available with different brush options.



Wanderhose

The wanderhose can be used to clean in places where the sweeper cannot reach. It has a length of 4.9 m with a diameter of 120 mm.



Camera system

Increases safety and line of sight at the suction intake or when backing up, and reduces the risk of accidents with obstacles or traffic by displaying the video on the CSense and Smart-Con screens.



High pressure water system with hand lance

120 bar high pressure system for cleaning walls, staircases, posts, handrails and such, as well as the sweeper. The hand lance, water hose and an automatic reel are easily accessible via the flaps on the hopper.



Brush options

The Bucher CityCat V20 series can be equipped with different kinds of brushes like silent, weed or poly/steel, to suit every need. Brushes can be changed in no time with the quick change system.



Bucher CityCat V20 configuration

Bucher CityCat V20e configuration

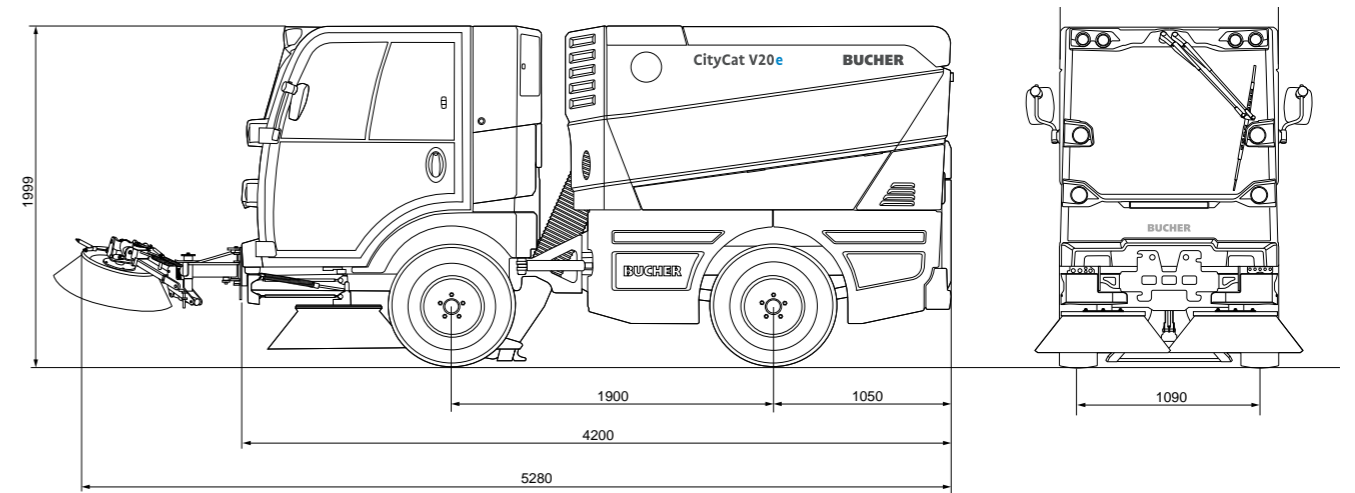
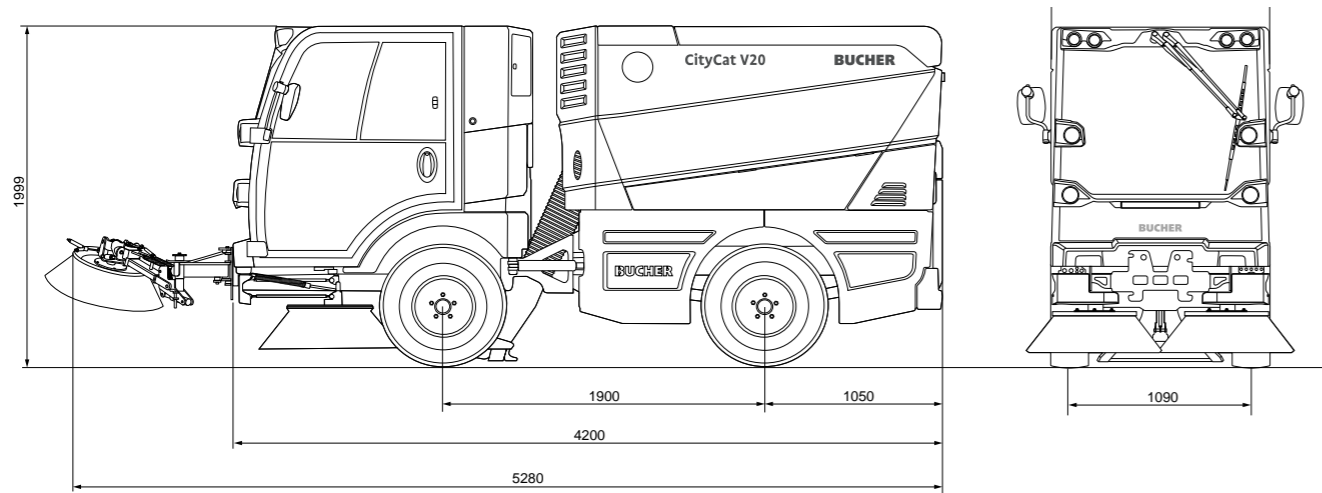

Dimensions

Length	4200 mm
Width	1300 mm
Height	1999 mm
Wheelbase	1900 mm
Track width	1090 mm
Cleaning width	2100 mm
Cleaning width 3rd brush	2700 mm

Weight

Empty weight	2700 kg
Payload	2100 kg
GVW	4800 kg

Emissions

Noise level L _{WA}	97 dB(A)
PM certification	PM 2.5/PM10 ****

Tyres

215/75 R16 C M+S

Drive system

Working speed	0-15 km/h
Travelling speed	0-50 km/h*
Climbing ability	up to 30 %

Stepless, hydrostatic drive system. Two speed levels with automatic, load-dependent electronic control.

Engine

Type	R754EU6D
Emission standard	Euro 6
Engine Displacement	2970 cm ³
Output	62 kW
Torque	270 Nm
Fuel tank	80 l
AdBlue tank	14 l
Electrical system	12 V
Battery	95 Ah

* According to national legislation

Dimensions

Length	4200 mm
Width	1300 mm
Height	1999 mm
Wheelbase	1900 mm
Track width	1090 mm
Cleaning width	2100 mm
Cleaning width 3rd brush	2700 mm

Weight

Empty weight	2700 kg
Payload	2100 kg
GVW	4800 kg

Emissions

Noise level L _{WA}	92 dB(A)
PM certification	PM 2.5/PM10 ****

Tyres

215/75 R16 C M+S

Drive system

Working speed	0-15 km/h
Travelling speed	0-50 km/h*
Climbing ability	up to 30 %

Electric drive	88 kW
Electric fan	8.5 kW
Electric hydraulic aggregate	12 kW

HV Battery

Battery type	Li-ion
Battery capacity	63 kWh
Nominal voltage	335 Volt
Operating time	up to 10 hours

Charging system

Internal charger	22 kW
Charger inlet	Type 2
Charging time	2 to 3 hours

* According to national legislation

Get Connected

Bucher Connect is a holistic after sales solution. A leading fleet management system, with comprehensive care and a digital platform for your repair and service planning – all in one simple package.

Using Bucher Connect makes the daily workload much easier for owners and managers of any fleet size. Our all-inclusive service offers targeted support and services for street cleaning and clearing operations, to minimise downtime and costs through the optimal efficiency of vehicles and equipment.

One connection **Many benefits**

Combining a digital platform with the complete after sales service, Bucher Connect has everything you need to operate your fleet at its best. It can be perfectly tailored to your needs through five different packages, as well as additional services and products.

Digital platform

Featuring two components, our «Fleet» module displays current machine positions, error messages with repair suggestions and important vehicle parameters, while «Service» takes care of all your repair and service needs.

This is supplemented by the two role-specific modules: «Jobs» and «Analytics». On a road map, route planning and road sweeps are marked in different colours for easy handling, with individual tracks via the address search.

«Fleet» for a detailed overview

- Current vehicle status and GPS position to give an overview of the fleet and detect potential breakdowns early
- Automatic fault alerts and digital support to enable quick resolution
- Service reminders for efficient workshop planning

«Jobs» for route planning and monitoring

- Digital cleaning report instead of manual operating logs and «On the route» KPIs for track

«Analytics» for fleet optimisation

- Optimise uptime for improved fleet productivity
- Optimise energy demand for improved sustainability and lower costs
- Easy reporting of vehicle data

«Service» for repair and service planning

- Access to the e-shop, workshop manuals and maintenance plans for optimal service
- One touch point for all your repair and service needs

Maintenance and repair

The maintenance and repair service enables you to focus on core business. Your maintenance partner carries out maintenance in accordance with factory specifications and uses trained service technicians, supporting you in procuring spare parts and providing remote support to reduce downtime.

Digital spare parts procurement

- Proactive service announcement
- Automatic service parts delivery to end-customers
- Time savings and prompt delivery for efficient workshop operation

Certified service

- Certified service and repair work for optimal fleet availability
- Comprehensive service and repair contract for predictable financial planning

Technical training

- Technical vehicle training
- Efficient vehicle use and higher first-time fix rate

Remote support and diagnostics

- Reduced downtime for optimal fleet use



Bucher CityCat V20e - Honoured by various **design & innovation awards** for its formally and functionally reflection of the claim to sustainability, advanced technology, functionality and user-friendliness.



reddot winner 2021



reddot winner 2021
innovative product



GERMAN
DESIGN
AWARD
SPECIAL
2021



GERMAN
INNO
VATION
AWARD '21
WINNER

Bucher Municipal



For local support,
please scan QR code
or visit

buchermunicipal.com

At Bucher Municipal, we innovate and engineer better cleaning and clearing solutions, helping our customers grow and maintain efficient and profitable businesses. Leveraging the over 200-year-old heritage of Bucher, we are committed to helping you achieve more using less. Taking pride in being seen as a reliable partner, we work locally with you in realising the possibilities for a smarter, cleaner and more efficient tomorrow. Today.



Your Bucher Municipal contract partner:

Driven by better



Bucher
Municipal
E-Shop